

1" to 3.5" 25 mm to 90 mm

NON SELF OILING GUNMETAL HEAVY DUTY PLUMMER BLOCKS

Non-Self-Oiling plummer blocks,

This Engineers range of split brass rigid heavy duty plain bearings were originally produced and designed by Christy Hunt of Colchester, All design drawings and stock were purchased by Criptic Arvis.

The Gunmetal split inserts are precision machined and fitted into the cast iron housings. The gunmetal inserts are replaceable without the need to replace the housing..

NOTE: These units were originally made to inch dimensions. The same castings are used for imperial & metric sizes and '2 times' rule applies only to the inch dimensions. Therefore, the distances through the metric bores are 2 times the inch sizes

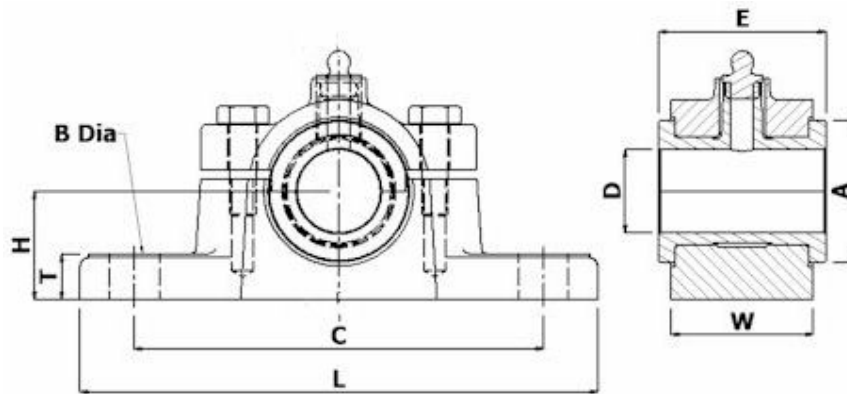

D	DIMENSIONS INCHES												
	Inch	MM	ORDER REF	L	E	A	L	C	H	W	T	B (MM)	Weight Kg
1	25	EN16E EN25	S3793	2 50	1 7/8 50	7 1/4 185	5 7/8 150	1 3/8 35	1 7/16 35	5/8 16	M10	2.	1/8
1 1/4	30	EN20E EN30M	S3797	2 1/4 65	7 55	7 3/4 200	5 7/8 150	1 5/8 41	1 11/16 45	11/16 17	M10	3.5	
1 1/2	30	EN24E EN35M EN40M	S3801	3 75	2 5/8 65	8 3/8 213	6 7/16 165	1 7/8 48	1 15/16 50	13/16 21	M12	4.5	
1 3/4	45	EN24E EN45M	S3805	3 1/2 90	2 7/8 75	10 3/4 275	8 1/4 210	2 1/8 54	2 7/16 60	7/8 22	M12	6.5	
2	50	EN32E EN50M	S3809	4 100	3 1/4 85	11 3/4 300	9 230	2 3/8 60	2 7/8 75	15/16 24	M16	9.5	
2 1/4	55	EN36E EN55M	S3813	4 1/2 115	3 3/8 90	12 11/16 325	9 13/16	3 76.2	2 5/8 65	1 1/4 30	M16	12.5	
2 1/2	60 65	EN40E EN60M EN65M	S3817	5 125	4 100	13 1/2 345	10 5/8 270	2 3/4 70	3 3/4 95	1 1/8 30	M20	16	
2 3/4	70	EN44E EN70M	S3821	5 1/2 140	4 1/4 110	14 1/4 360	11 1/4 285	3 76	4 1/4 110	1 3/16 30	M20	21.7	
3	75	EN48E EN75M	S3825	6 150	4 1/4 115	15 1/8 385	11 1/4 300	3 1/4 83	4 5/8 115	1 1/4 30	M20	27.2	
3 1/4	80 85	EN52E EN80M EN85M	S3829	6 1/2 165	5 125	15 7/8 405	12 5/8 320	3 1/2 89	5 125	1 5/16 35	M24	33.2	
3 1/2	90	EN56E EN90M	S3833	7 180	5 3/8 135	16 3/4 425	13 1/4 335	3 3/4 95	5 3/8 135	1 3/8 35	M24	40.4	

Customised versions of these units can be supplied - Specials made to order.